

HV48100 15S Cabinet Installation Guide

Step 1

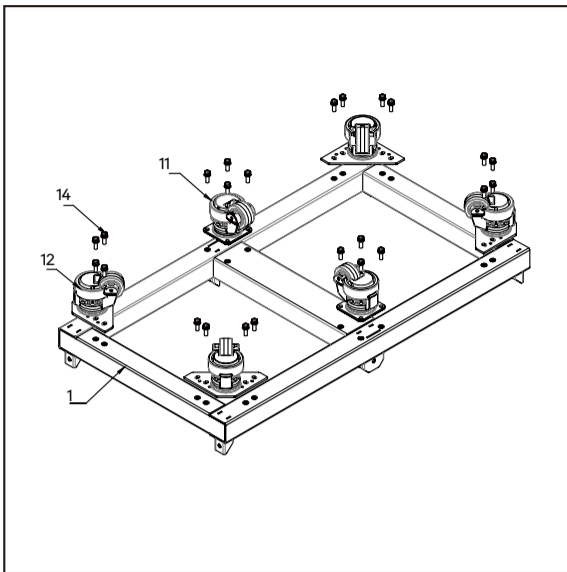

Install the Fuma Wheels to bottom of base frame with screws.
Tighten the screws (Torque 18Nm).

Step 2

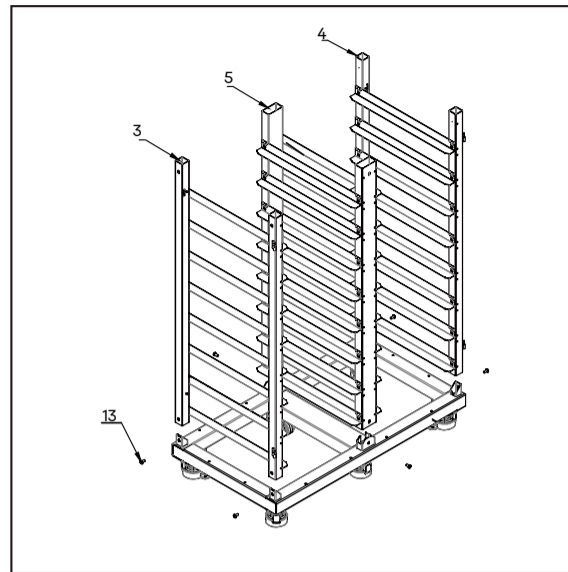

Install 3,4,5 frames to base frame and pre-tighten screws.

Step 3

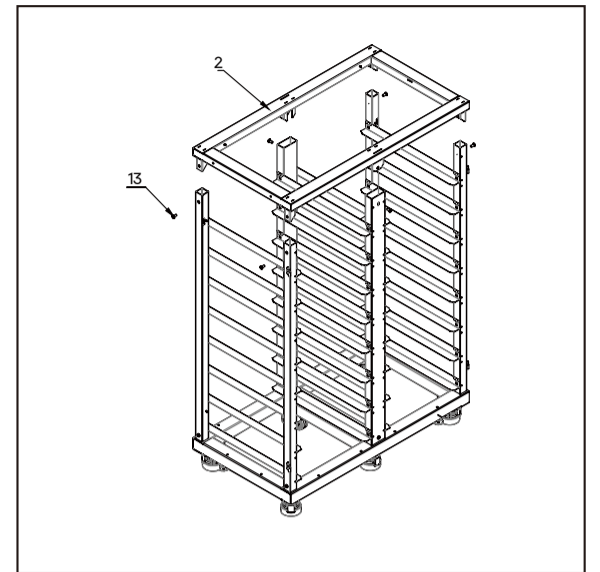

Install the top frame and tighten all the screws, including 3,4,5 frames. (Torque 18Nm)

Step 4

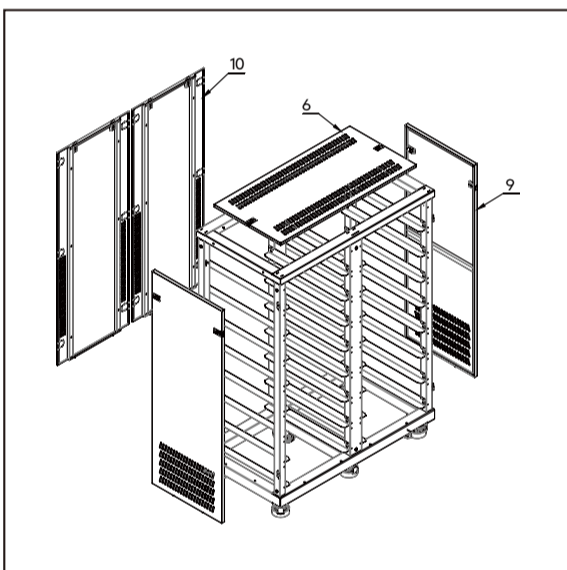

Install the top cover, side panels and back panel.

Step 5

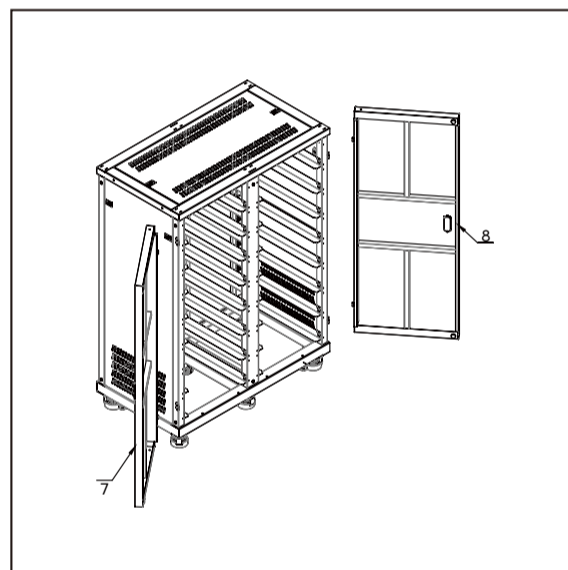

Install the cabinet doors.

Step 6

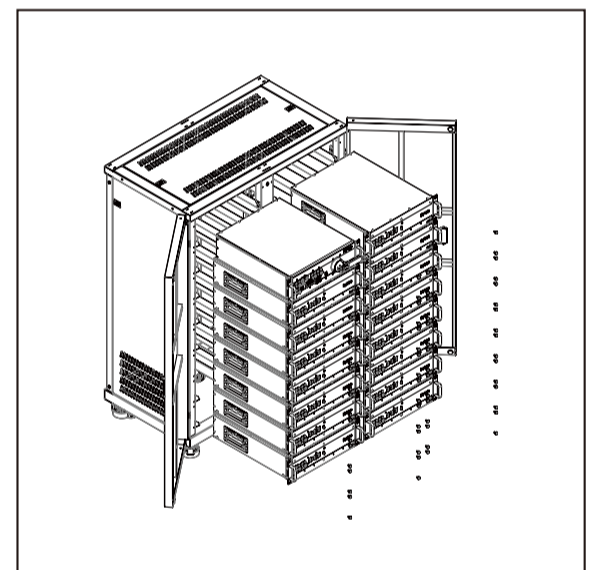

Place HV48100 to the cabinet, and tighten each module to cabinet with screws (Torque 9Nm)

Step 7

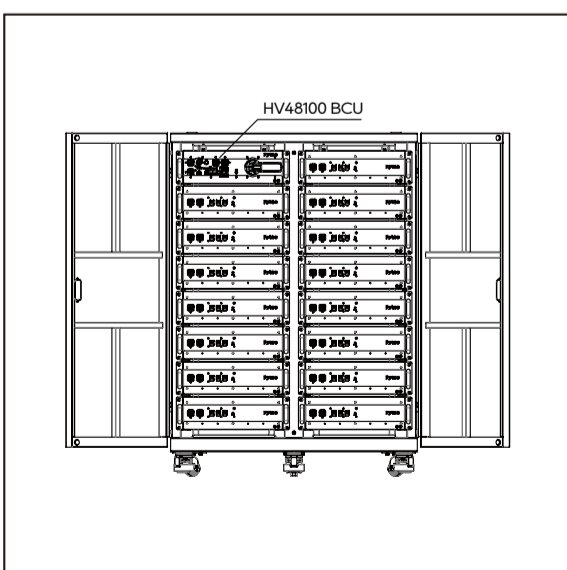





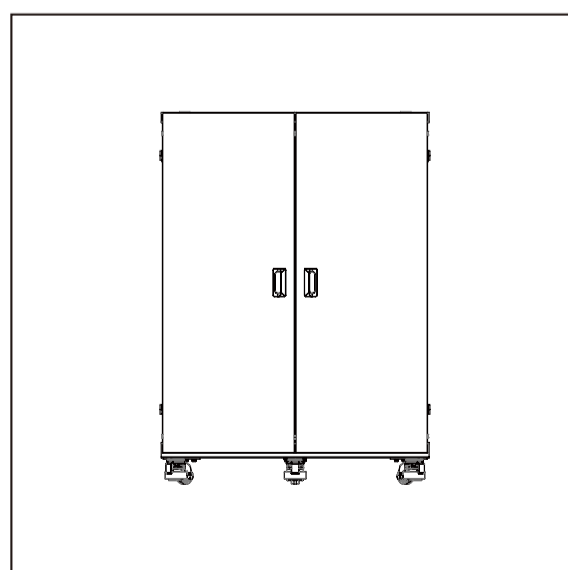





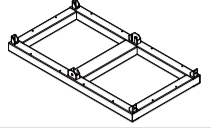
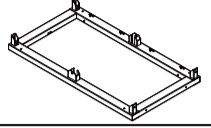
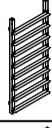
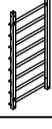

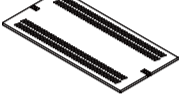

Cabling.

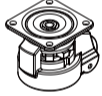
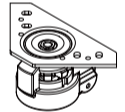
Step 8



Done.

Packing List

No.	Item	Specification	QTY	Picture
1	HV48100 15S Cabinet Base Frame	41.5"×22.83"×4.21" (1054×580×107mm)	1	
2	HV48100 15S Cabinet Top Frame	41.5"×22.83"×4.04" (1054×580×102.5mm)	1	
3	HV48100 15S Cabinet Frame A	22.05"×3.15"×49.61" (560×80×1260mm)	1	
4	HV48100 15S Cabinet Frame B	22.05"×3.15"×49.61" (560×80×1260mm)	1	
5	HV48100 15S Cabinet Middle Frame	22.05"×6.3"×49.61" (560×160×1260mm)	1	
6	HV48100 15S Cabinet Top Cover	36.65"×17.99"×0.591" (931×457×15mm)	1	
7	HV48100 15S Cabinet Door A	20.47"×2.17"×52.76" (520×55×1340mm)	1	
8	HV48100 15S Cabinet Door B	20.47"×2.17"×52.76" (520×55×1340mm)	1	
9	HV48100 15S Cabinet Side Panel	18.78"×0.787"×52.76" (477×20×1259mm)	2	
10	HV48100 15S Cabinet Back Panel	19.41"×0.709"×49.57" (493×18×1259mm)	2	
11	Fuma Wheel GD-80-F	3.54"×4.76"×4.8" (90×121×122mm)	2	
12	Fuma Wheel YS-80T	5.71"×5.71"×4.8" (145×145×122mm)	4	
13	Screws for Cabinet	YJT 4026 M8×0.63" (16mm)	12	
14	Screws for Wheels to Cabinet	GB 9074.13-1988 M8×0.95" (25mm)	24	
15	Strapping belt	F07	5	
16	Warning Lable	2.0"×3.9"(50×100mm)	6	
17	Communication Cable	CAT6 UTP 8 Cores Communication Cable-25.4"(645mm)-RJ45×2	1	
18	Power Cable B-	UL 10269-4AWG-22.05"(560mm) Amphenol×2	1	
19	Serial Connection Power Cable	UL 10269-4AWG-24.8"(630mm) Amphenol×2	1	
20	Ground Cable	UL 1015-10AWG-22.05"(560mm) SC6-6×2	1	

Tools to Prepare

